



LANDMARK UNIVERSITY, OMU-ARAN

LECTURE NOTE: 3

COLLEGE: COLLEGE OF SCIENCE AND ENGINEERING

DEPARTMENT: MECHANICAL ENGINEERING

PROGRAMME: MECHANICAL ENGINEERING

ENGR. ALIYU, S.J

Course code: MCE 314

Course title: WORKSHOP PRACTICE

Credit unit: 2 UNITS.

Course status: compulsory

LATHE MACHINE

1 INTRODUCTION

Lathe is one of the most versatile and widely used machine tools all over the world. It is commonly known as the mother of all other machine tool. The main function of a lathe is to remove metal from a job to give it the required shape and size. The job is securely and rigidly held in the chuck or in between centers on the lathe machine and then turn it against a single point cutting tool which will remove metal from the job in the form of chips. Fig. 1 shows the working principle of lathe. An engine lathe is the most basic and simplest form of the lathe. It derives its name from the early lathes, which obtained their power from engines. Besides the simple turning operation as described above, lathe can be used to carry out other operations also, such as drilling, reaming, boring, taper turning, knurling, screw thread cutting, grinding etc.

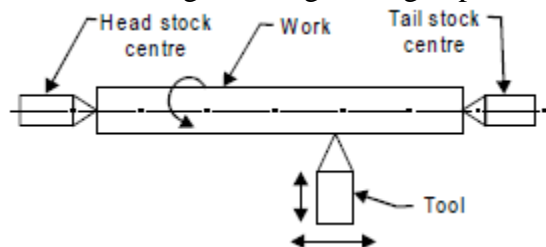

Fig. 1 Working principal of lathe machine

2 TYPES OF LATHE

Lathes are manufactured in a variety of types and sizes, from very small bench lathes used for precision work to huge lathes used for turning large steel shafts. But the principle of operation and function of all types of lathes is same. The different types of lathes are:

1. Speed lathe
 - (a) Wood working
 - (b) Spinning
 - (c) Centering
 - (d) Polishing

2. Centre or engine lathe
 - (a) Belt drive
 - (b) Individual motor drive
 - (c) Gear head lathe
3. Bench lathe
4. Tool room Lathe
5. Capstan and Turret lathe
6. Special purpose lathe
 - (a) Wheel lathe
 - (b) Gap bed lathe
 - (c) Duplicating lathe
 - (d) T-lathe
7. Automatic lathe

Some of common lathes are described as under.

2.1 Speed Lathe

Speed lathe is simplest of all types of lathes in construction and operation. The important parts of speed lathe are following-

- (1) Bed
- (2) Headstock
- (3) Tailstock, and
- (4) Tool post mounted on an adjustable slide.

It has no feed box, leadscrew or conventional type of carriage. The tool is mounted on the adjustable slide and is fed into the work by hand control. The speed lathe finds applications where cutting force is least such as in wood working, spinning, centering, polishing, winding, buffing etc.

This lathe has been so named because of the very high speed of the headstock spindle.

2.2 Centre Lathe or Engine Lathe

The term “engine” is associated with this lathe due to the fact that in the very early days of its development it was driven by steam engine. This lathe is the important member of the lathe family and is the most widely used. Similar to the speed lathe, the engine lathe has all the basic parts, e.g., bed, headstock, and tailstock. But its headstock is much more robust in construction and contains additional mechanism for driving the lathe spindle at multiple speeds. An engine lathe is shown in Fig. 2. Unlike the speed lathe, the engine lathe can feed the cutting tool both in cross and longitudinal direction with reference to the lathe axis with the help of a carriage, feed rod and lead screw. Centre lathes or engine lathes are classified according to methods of transmitting power to the machine. The power may be transmitted by means of belt, electric motor or through gears.

2.3 Bench Lathe

This is a small lathe usually mounted on a bench. It has practically all the parts of an engine lathe or speed lathe and it performs almost all the operations. This is used for small and precision work.

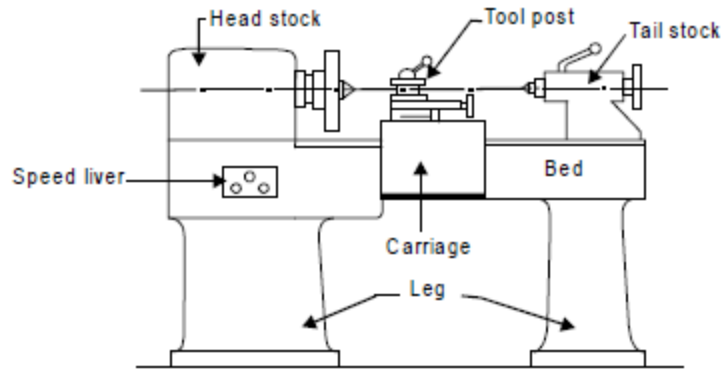

Fig. 2 Principal components of a central lathe

2.4 Tool Room Lathe

This lathe has features similar to an engine lathe but it is much more accurately built. It has a wide range of spindle speeds ranging from a very low to a quite high speed up to 2500 rpm. This lathe is mainly used for precision work on tools, dies, gauges and in machining work where accuracy is needed.

2.5 Capstan and Turret Lathe

The development of these lathes results from the technological advancement of the engine lathe and these are vastly used for mass production work. The distinguishing feature of this type of lathe is that the tailstock of an engine lathe is replaced by a hexagonal turret, on the face of which multiple tools may be fitted and fed into the work in proper sequence. Due to this arrangement, several different types of operations can be done on a job without re-setting of work or tools, and a number of identical parts can be produced in the minimum time.

2.6 Special Purpose Lathes

These lathes are constructed for special purposes and for jobs, which cannot be accommodated or conveniently machined on a standard lathe. The wheel lathe is made for finishing the journals and turning the tread on railroad car and locomotive wheels. The gap bed lathe, in which a section of the bed adjacent to the headstock is removable, is used to swing extra-large-diameter pieces. The T-lathe is used for machining of rotors for jet engines. The bed of this lathe has T-shape. Duplicating lathe is one for duplicating the shape of a flat or round template on to the job.

2.7 Automatic Lathes

These lathes are so designed that all the working and job handling movements of the complete manufacturing process for a job are done automatically. These are high speed, heavy duty, mass production lathes with complete automatic control.

3 CONSTRUCTION OF LATHE MACHINE

A simple lathe comprises of a bed made of grey cast iron on which headstock, tailstock, carriage and other components of lathe are mounted. Fig. 3 shows the different parts of engine lathe or central lathe. The major parts of lathe machine are given as under:

1. Bed
2. Head stock
3. Tailstock
4. Carriage
5. Feed mechanism
6. Thread cutting mechanism

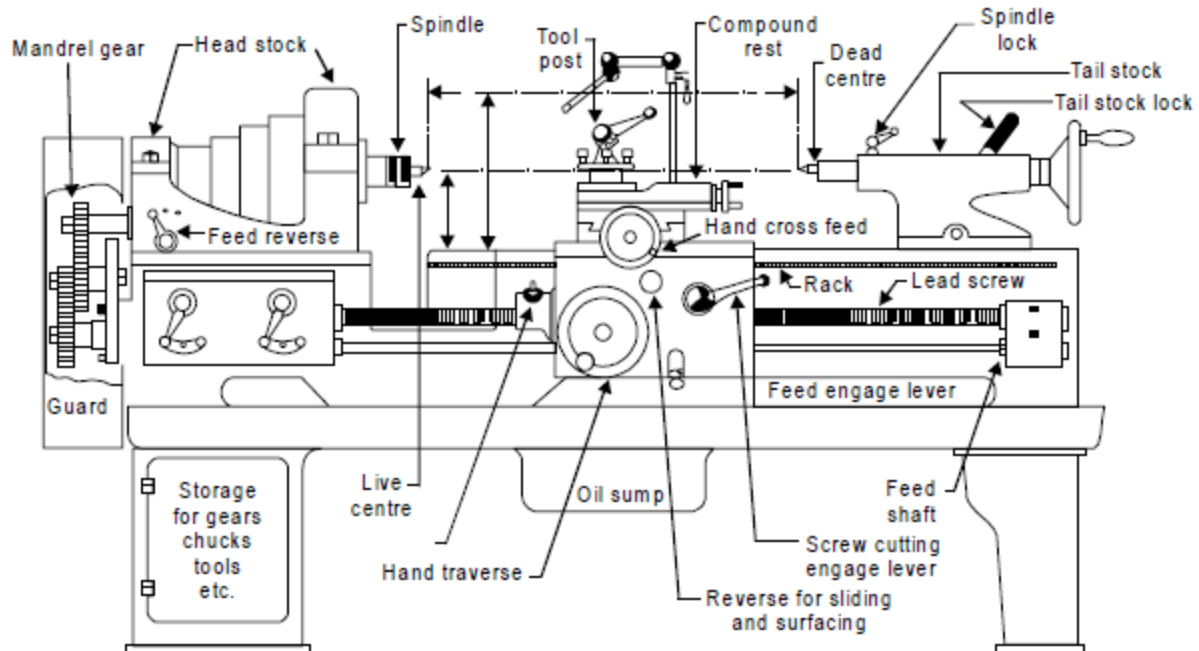

Fig. 3 Different parts of engine lathe or central lathe

3.1 Bed

The bed of a lathe machine is the base on which all other parts of lathe are mounted. It is massive and rigid single piece casting made to support other active parts of lathe. On left end of the bed, headstock of lathe machine is located while on right side tailstock is located. The carriage of the machine rests over the bed and slides on it. On the top of the bed there are two sets of guide ways-inner ways and outer ways. The inner ways provide sliding surfaces for the tailstock and the outer ways for the carriage. The guide ways of the lathe bed may be flat and inverted V shape. Generally cast iron alloyed with nickel and chromium material is used for manufacturing of the lathe bed.

3.2 Head Stock

The main function of headstock is to transmit power to the different parts of a lathe. It comprises of the headstock casting to accommodate all the parts within it including gear train arrangement. The main spindle is adjusted in it, which possesses live centre to which the work can be attached. It supports the work and revolves with the work, fitted into the main spindle of the headstock. The cone pulley is also attached with this arrangement, which is used to get various spindle speed through electric motor. The back gear arrangement is used for obtaining a wide range of slower speeds. Some gears called change wheels are used to produce different velocity ratio required for thread cutting.

3.3 Tail Stock

Fig. 4 shows the tail stock of central lathe, which is commonly used for the objective of primarily giving an outer bearing and support the circular job being turned on centers. Tail stock can be easily set or adjusted for alignment or non-alignment with respect to the spindle centre and carries a centre called dead centre for supporting one end of the work. Both live and dead centers have 60° conical points to fit centre holes in the circular job, the other end tapering to allow for good fitting into the spindles. The dead centre can be mounted in ball bearing so that it rotates with the job avoiding friction of the job with dead centre as it important to hold heavy jobs.

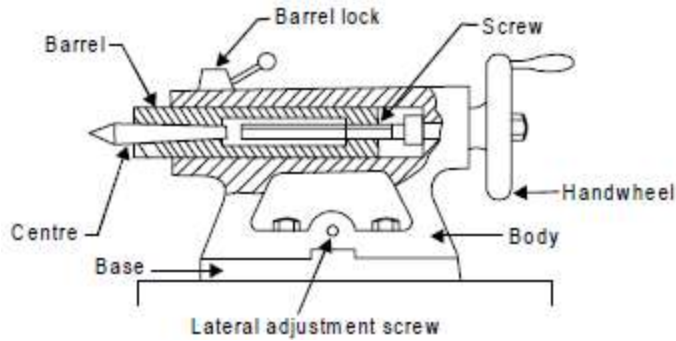

Fig. 4 Tail stock of central lathe.

3.4 Carriage

Carriage is mounted on the outer guide ways of lathe bed and it can move in a direction parallel to the spindle axis. It comprises of important parts such as apron, cross-slide, saddle, compound rest, and tool post. The lower part of the carriage is termed the apron in which there are gears to constitute apron mechanism for adjusting the direction of the feed using clutch mechanism and the split half nut for automatic feed. The cross-slide is basically mounted on the carriage, which generally travels at right angles to the spindle axis. On the cross-slide, a saddle is mounted in which the compound rest is adjusted which can rotate and fix to any desired angle. The compound rest slide is actuated by a screw, which rotates in a nut fixed to the saddle. The tool post is an important part of carriage, which fits in a tee-slot in the compound rest and holds the tool holder in place by the tool post screw. Fig. 5 shows the tool post of centre lathe.

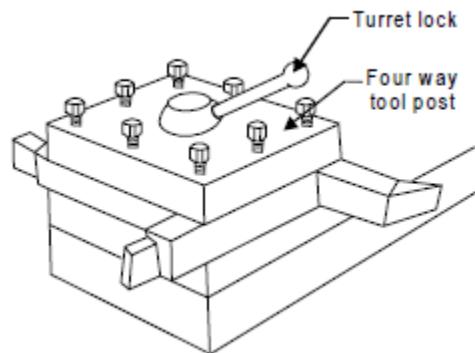

Fig. 5 Tool post of centre lathe

3.5 Feed Mechanism

Feed mechanism is the combination of different units through which motion of headstock spindle is transmitted to the carriage of lathe machine. Following units play role in feed mechanism of a lathe machine-

1. End of bed gearing
2. Feed gear box
3. Lead screw and feed rod
4. Apron mechanism

The gearing at the end of bed transmits the rotary motion of headstock spindle to the feed gear box. Through the feed gear box the motion is further transmitted either to the feed shaft or lead screw, depending on whether the lathe machine is being used for plain turning or screw cutting. The feed gear box contains a number of different sizes of gears. The feed gear box provides a means to alter the rate of feed, and the ration between revolutions of the headstock spindle and the movement of carriage for thread cutting by changing the speed of rotation of the feed rod or lead screw. The apron is fitted to the saddle. It contains gears and clutches to transmit motion from the feed rod to the carriage, and the half nut which engages with the lead screw during cutting threads.

3.6 Thread Cutting Mechanism

The half nut or split nut is used for thread cutting in a lathe. It engages or disengages the carriage with the lead screw so that the rotation of the lead screw is used to traverse the tool along the work-piece to cut screw threads. The direction in which the carriage moves depends upon the position of the feed reverse lever on the headstock.

4 ACCESSORIES AND ATTACHMENTS OF LATHE

There are many lathe accessories provided by the lathe manufacturer along with the lathe, which support the lathe operations. The important lathe accessories include centers, catch plates and carriers, chucks, collets, face plates, angle plates, mandrels, and rests. These are used either for holding and supporting the work or for holding the tool. Attachments are additional equipments provided by the lathe manufacturer along with the lathe, which can be used for specific operations. The lathe attachment include stops, ball turning rests, thread chasing dials, milling attachment, grinding attachment, gear cutting attachment, turret attachment and crank pin turning attachments and taper turning attachment.

Lathe centers

The most common method of holding the job in a lathe is between the two centers generally known as live centre (head stock centre) and dead centre (tailstock centre). They are made of very hard materials to resist deflection and wear and they are used to hold and support the cylindrical jobs.

Carriers or driving dog and catch plates

These are used to drive a job when it is held between two centers. Carriers or driving dogs are attached to the end of the job by a setscrew. A use of lathe dog for holding and supporting the job is shown in Fig. 6. Catch plates are either screwed or bolted to the nose of the headstock spindle. A projecting pin from the catch plate or carrier fits into the slot provided in either of them. This imparts a positive drive between the lathe spindle and job.

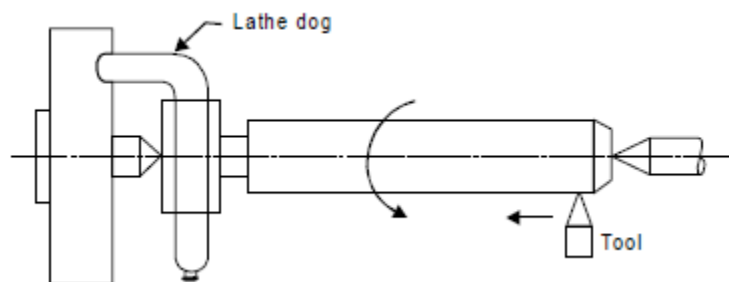

Fig. 21.6 Lathe dog

Chucks

Chuck is one of the most important devices for holding and rotating a job in a lathe. It is basically attached to the headstock spindle of the lathe. The internal threads in the chuck fit on to the external threads on the spindle nose. Short, cylindrical, hollow objects or those of irregular shapes, which cannot be conveniently mounted between centers, are easily and rigidly held in a chuck. Jobs of short length and large diameter or of irregular shape, which cannot be conveniently mounted between centers, are held quickly and rigidly in a chuck.

There are a number of types of lathe chucks, e.g.

- (1) Three jaws or universal
- (2) Four jaw independent chuck
- (3) Magnetic chuck
- (4) Collet chuck
- (5) Air or hydraulic chuck operated chuck
- (6) Combination chuck
- (7) Drill chuck.

Face plates

Face plates are employed for holding jobs, which cannot be conveniently held between centers or by chucks. A face plate possesses the radial, plain and T slots for holding jobs or work-pieces by bolts and clamps. Face plates consist of a circular disc bored out and threaded to fit the nose of the lathe spindle. They are heavily constructed and have strong thick ribs on the back. They have slots cut into them, therefore nuts, bolts, clamps and angles are used to hold the jobs on the face plate. They are accurately machined and ground.

Angle plates

Angle plate is a cast iron plate having two faces machined to make them absolutely at right angles to each other. Holes and slots are provided on both faces so that it may be clamped on a faceplate and can hold the job or work-piece on the other face by bolts and clamps. The plates are used in conjunction with a face plate when the holding surface of the job should be kept horizontal.

Mandrels

A mandrel is a device used for holding and rotating a hollow job that has been previously drilled or bored. The job revolves with the mandrel, which is mounted between two centers. It is rotated by the lathe dog and the catch plate and it drives the work by friction. Different types of mandrels are employed according to specific requirements. It is hardened and tempered steel shaft or bar with 60° centers, so that it can be mounted between centers. It holds and locates a part from its center hole. The mandrel is always rotated with the help of a lathe dog; it is never placed in a chuck for turning the job. A mandrel unlike an arbor is a job holding device rather than a cutting tool holder. A bush can be faced and turned by holding the same on a mandrel between centers. It is generally used in order to machine the entire length of a hollow job

Rests

A rest is a lathe device, which supports a long slender job, when it is turned between centers or by a chuck, at some intermediate point to prevent bending of the job due to its own weight and vibration set up due to the cutting force that acts on it. The two types of rests commonly used for supporting a long job in an engine lathe are the steady or centre rest and the follower rest.

5 SPECIFICATION OF LATHE

The size of a lathe is generally specified by the following means:

- (a) Swing or maximum diameter that can be rotated over the bed ways
- (b) Maximum length of the job that can be held between head stock and tail stock centres

- (c) Bed length, which may include head stock length also
 - (d) Maximum diameter of the bar that can pass through spindle or collect chuck of capstan lathe.
- Fig.7 illustrates the elements involved in specifications of a lathe. The following data also contributes to specify a common lathe machine.

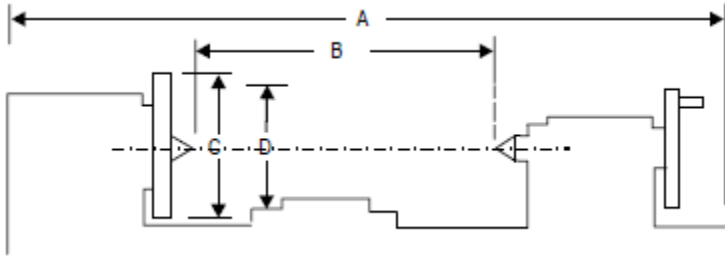

Fig. 7 Specifications of a lathe

- A - Length of bed.
- B - Distance between centres.
- C - Diameter of the work that can be turned over the ways.
- D - Diameter of the work that can be turned over the cross slide.

- (i) Maximum swing over bed
- (ii) Maximum swing over carriage
- (iii) Height of centers over bed
- (iv) Maximum distance between centers
- (v) Length of bed
- (vi) Width of bed
- (vii) Morse taper of center
- (viii) Diameter of hole through spindle
- (ix) Face plate diameter
- (x) Size of tool post
- (xi) Number of spindle speeds
- (xii) Lead screw diameter and number of threads per cm.
- (xiii) Size of electrical motor
- (xiv) Pitch range of metric and inch threads etc.

6 LATHE OPERATIONS

For performing the various machining operations in a lathe, the job is being supported and driven by anyone of the following methods.

1. Job is held and driven by chuck with the other end supported on the tail stock centre.
2. Job is held between centers and driven by carriers and catch plates.
3. Job is held on a mandrel, which is supported between centers and driven by carriers and catch plates.
4. Job is held and driven by a chuck or a faceplate or an angle plate. The above methods for holding the job can be classified under two headings namely job held between centers and job held by a chuck or any other fixture. The various important lathe operations are depicted through Fig. 8 (a), (b) and (c). The operations performed in a lathe can be understood by three major categories.

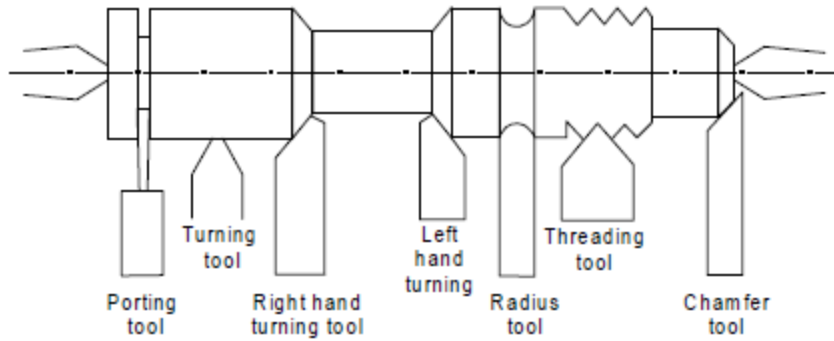

Fig. 8(a) Lathe operation

(a) Operations, which can be performed in a lathe either by holding the work-piece between centers or by a chuck are:

- | | |
|----------------------|---------------------|
| 1. Straight turning | 2. Shoulder turning |
| 3. Taper turning | 4. Chamfering |
| 5. Eccentric turning | 6. Thread cutting |
| 7. Facing | 8. Forming |
| 9. Filing | 10. Polishing |
| 11. Grooving | 12. Knurling |
| 13. Spinning | 14. Spring winding |

(b) Operations which are performed by holding the work by a chuck or a faceplate or an angle plate are:

- | | |
|----------------------------|-----------------|
| 1. Undercutting | 2. Parting-off |
| 3. Internal thread cutting | 4. Drilling |
| 5. Reaming | 6. Boring |
| 7. Counter boring | 8. Taper boring |
| 9. Tapping | |

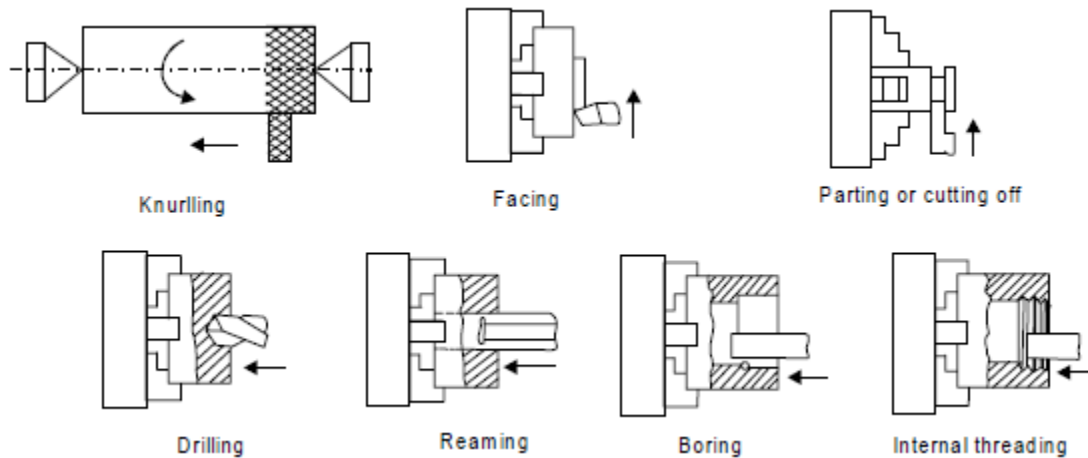

Fig. 8(b) Lathe operations

(c) Operations which are performed by using special lathe attachments are:

- | | |
|------------|-------------|
| 1. Milling | 2. Grinding |
|------------|-------------|

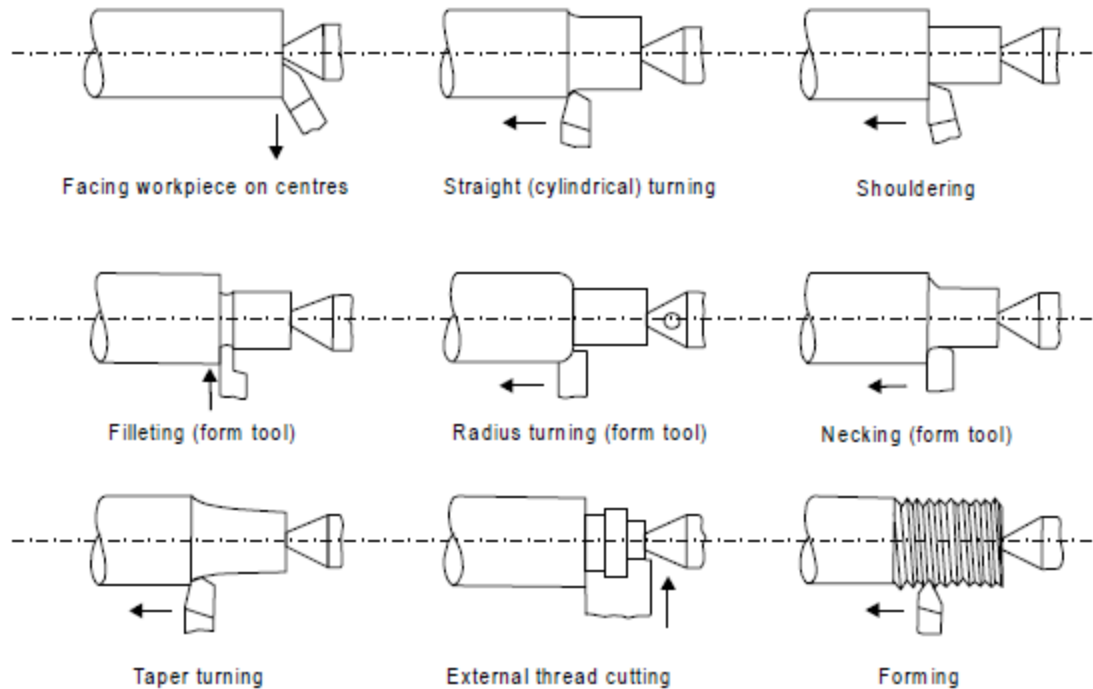

Fig. 8(c) Lathe operation

Some of the important operations performed on a lathe machine are discussed as under.

7 TAPERS AND TAPER TURNING

A taper is defined as a uniform increase or decrease in diameter of a piece of work measured along its length. In a lathe machine, taper turning means to produce a conical surface by gradual reduction in diameter from a cylindrical job. Taper in the British System is expressed in taper per foot or taper per inch.

$$\text{Taper per inch} = (D - d) / l$$

Where,

D = is the diameter of the large end of cylindrical job,

d = is the diameter of the small end of cylindrical job, and

l = is the length of the taper of cylindrical job, all expressed in inches,

When the taper is expressed in taper per foot, the length of the taper l is expressed in foot, but the diameters are expressed in inches. A taper is generally turned in a lathe by feeding the tool at an angle to the axis of rotation of the work-piece. The angle formed by the path of the tool with the axis of the work-piece should correspond to the half taper angle. A taper can be turned by anyone of the following methods:

1. By swiveling the compound rest,
2. By setting over the tailstock centre,
3. By a broad nose form tool,
4. By a taper turning attachment,
5. By combining longitudinal and cross feed in a special lathe and
6. By using numerical control lathe

Some of the important taper turning methods are discussed as under.

7.1 Taper Turning by Swivelling the Compound Rest

This method uses the principle of turning taper by rotating the work-piece on the lathe axis and feeding the tool at an angle to the axis of rotation of the work-piece. The tool is mounted on the

compound rest which is attached to a circular base, graduated in degrees. The compound rest can easily be swiveled or rotated and clamped at any desired angle as shown in Fig. 9 (a). Once the compound rest is set at the desired half taper angle, rotation of the compound slide screw will cause the tool to be fed at that angle and generate a corresponding taper. This method is limited to turn a short but steep taper because of the limited movement of the cross-slide. The compound rest can be swiveled at 45° on either side of the lathe axis enabling it to turn a steep taper. The movement of the single point cutting tool in this method is being purely controlled by hand. Thus it provides a low production capacity and poor surface finish. The positioning or setting of the compound rest is accomplished by swiveling the rest at the half taper angle, if this is already known. If the diameter of the small and large end and length of taper are known, the half taper angle can be calculated. The complete setup for producing a taper by swiveling the compound rest is given in Fig. 9(b)

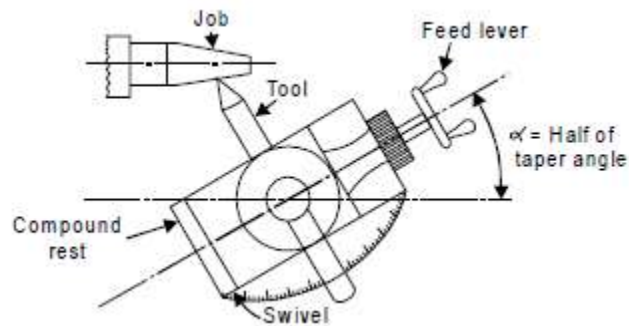

Fig. 9(a) Taper turning by swiveling compound rest

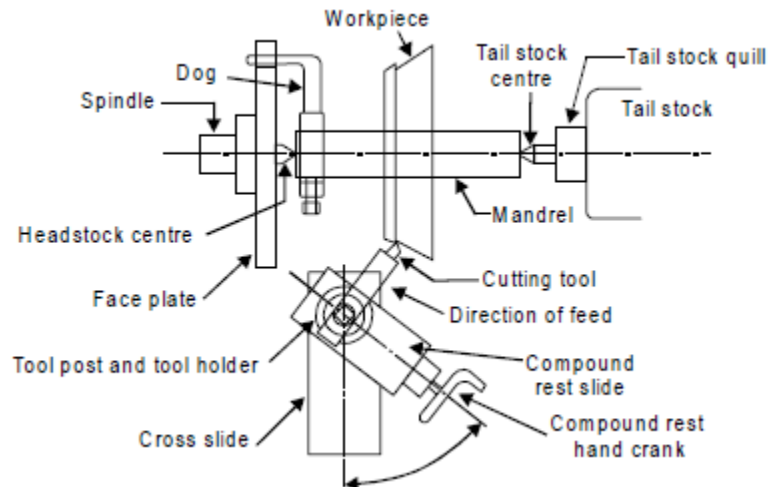

Fig. 9(b) Swiveling compound rest set-up

7.2 Taper Turning Attachment Method

This method is commonly employed for generating external tapers only. In this method, the taper turning attachment is bolted back of the lathe machine as shown in Fig.10. It has guide bar which may be set at any desired angle or taper. As the carriage moves along the bed lengthwise over bar causes the tool to move in and out according to setting of the bar. The taper setting on the bar is duplicated on the job or work. The merit of this method is that the lathe centres are kept in alignment.

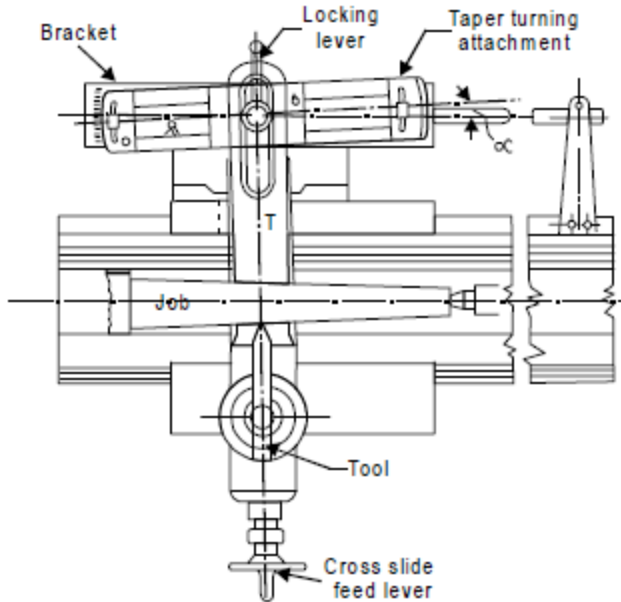

Fig. 10 Taper turning attachment

8 THREAD CUTTING

Fig.11 shows the setup of thread cutting on a lathe. Thread of any pitch, shape and size can be cut on a lathe using single point cutting tool. Thread cutting is operation of producing a helical groove on spindle shape such as V, square or power threads on a cylindrical surface. The job is held in between centres or in a chuck and the cutting tool is held on tool post. The cutting tool must travel a distance equal to the pitch (in mm) as the work piece completes a revolution. The definite relative rotary and linear motion between job and cutting tool is achieved by locking or engaging a carriage motion with lead screw and nut mechanism and fixing a gear ratio between head stock spindle and lead screw. To make or cut threads, the cutting tool is brought to the start of job and a small depth of cut is given to cutting tool using cross slide.

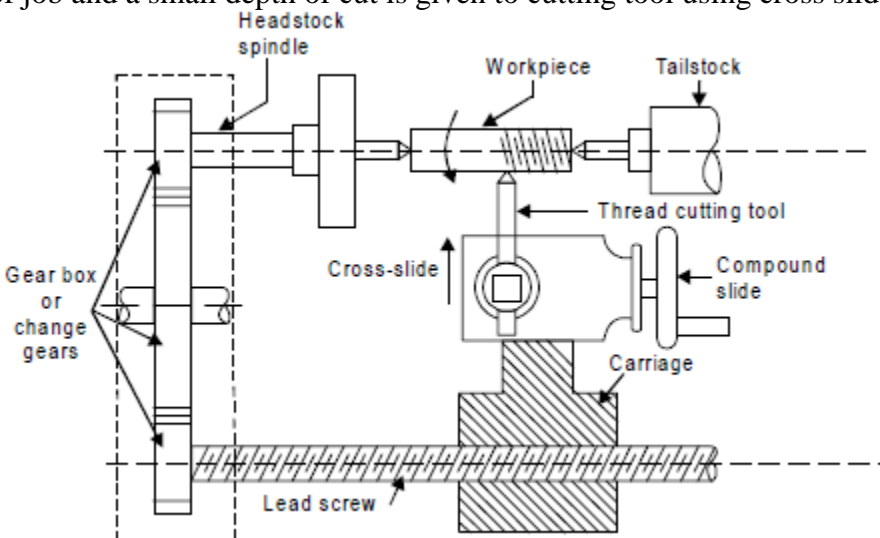

Fig. 11 Thread cutting

9 DRILLING ON A LATHE

For producing holes in jobs on lathe, the job is held in a chuck or on a face plate. The drill is held in the position of tailstock and which is brought nearer the job by moving the tailstock along the guide ways, the thus drill is fed against the rotating job as shown in Fig. 12.

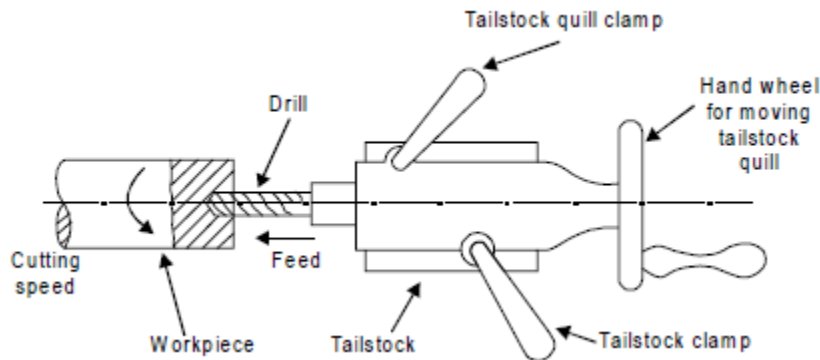

Fig. 12 Drilling on lathe

10 CUTTING SPEED

Cutting speed for lathe work may be defined as the rate in meters per minute at which the surface of the job moves past the cutting tool. Machining at a correct cutting speed is highly important for good tool life and efficient cutting. Too slow cutting speeds reduce productivity and increase manufacturing costs whereas too high cutting speeds result in overheating of the tool and premature failure of the cutting edge of the tool. The following factors affect the cutting speed:

- (i) Kind of material being cut,
- (ii) Cutting tool material,
- (iii) Shape of cutting tool,
- (iv) Rigidity of machine tool and the job piece and
- (v) Type of cutting fluid being used.

Calculation of cutting speed C_s , in meters per minute

$$C_s = ((22/7) \times D \times N) / 1000$$

Where

D is diameter of job in mm.

N is in RPM

11 FEED

Feed is defined as the distance that a tool advances into the work during one revolution of the headstock spindle. It is usually given as a linear movement per revolution of the spindle or job. During turning a job on the centre lathe, the saddle and the tool post move along the bed of the lathe for a particular feed for cutting along the length of the rotating job.

12 QUESTIONS

1. Describe the working principle of the lathe.
2. Name the different types of the lathes available in machine shop? Describe the working of a centre lathe.
3. Explain the parts of a centre lathe using neat sketch.
4. Explain following parts of a lathe by neat sketches:
 - (i) Lathe Bed (ii) Carriage (iii) Headstock (iv) Tailstock
5. How can you specify a lathe?
6. Name the operations, which can be performed on a lathe.
7. Lists the accessories of a lathe? Explain them with neat sketches.
8. Describe any two work holding devices used on the lathe.

9. What is the use of follower rest and steady rest?
10. Explain the difference between three jaw chuck and four jaw chuck.
11. Using neat sketches, describe the various operations that can be carried on lathe machines.
12. Discuss the merits and demerits of a geared-head drive over cone-pulley drive.
13. Name and sketch the different types of the cutting tools of the lathe.
14. Describe the procedure of cutting right hand V- heads of the lathe.
15. With help of neat diagram, describe the following:
 - (i) Finish turning
 - (ii) Rough turning
 - (iii) Turning
 - (iv) Drilling
 - (v) Attachments of lathe
16. Name different methods of taper turning? Describe these methods using neat sketches.
17. Describe with suitable sketch the procedure for turning a taper using setting over the tailstock.
18. Define the following terms used in lathe operation.
 - (i) Cutting speed
 - (ii) Feed
 - (iii) Depth of cut
 - (iv) Machining time